

Name	Signatur	Datum	Artikelnummer	Oberfläche: Geschliffen Korn 240
Ch. Höfig	CH	08.02.2022	88.1160495.240	
Werkstoff:				Blattformat
1.4301 (X5CrNi18-10)				A4
Gewicht 0.200 kg		Maßstab: 1:2,25 Version: 1		Blatt 1 von 6

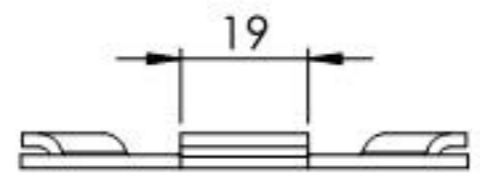

Name	Signatur	Datum	Artikelnummer	Oberfläche: Roh
Ch. Höfig	CH	08.02.2022	88.1160495.240	
Werkstoff:				Blattformat
1.4301 (X5CrNi18-10)				A4
Gewicht 0.054 kg		Maßstab: 1:1.5 Version: 1		Blatt 2 von 6

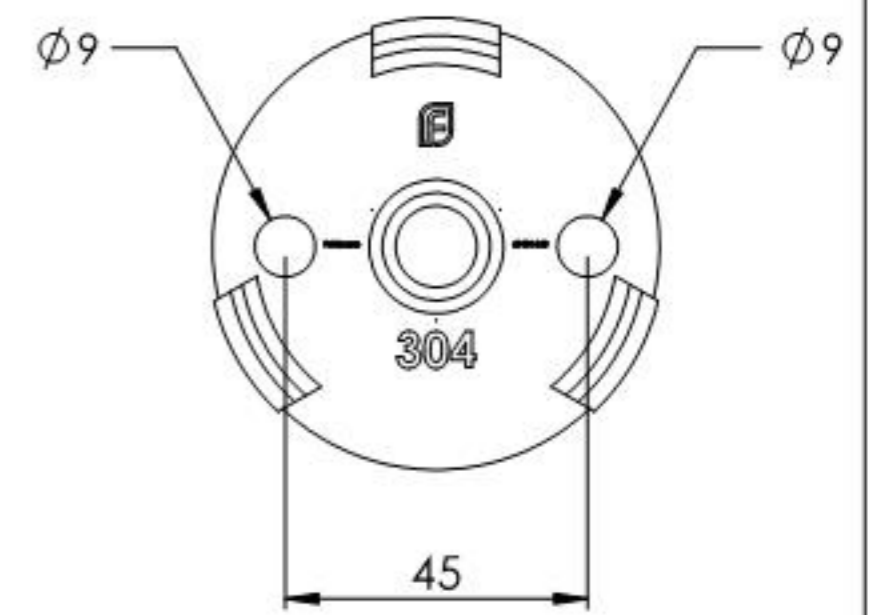
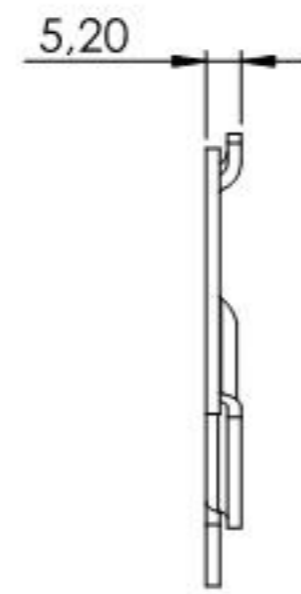
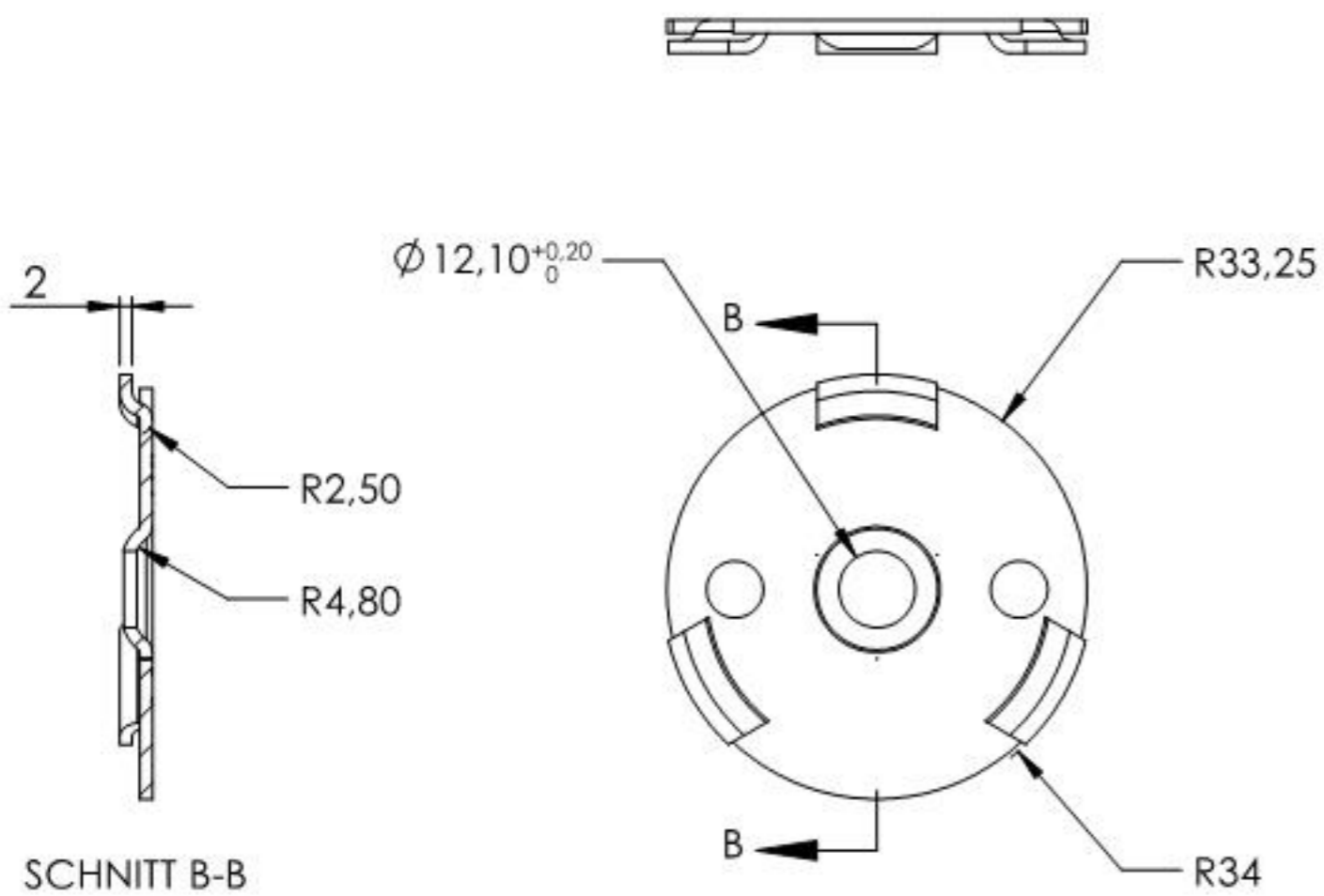
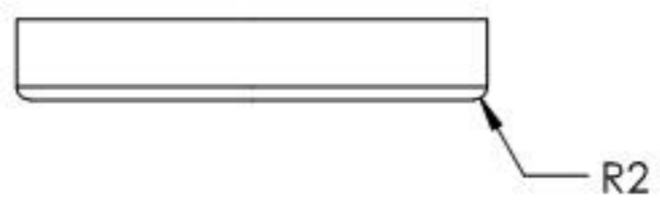
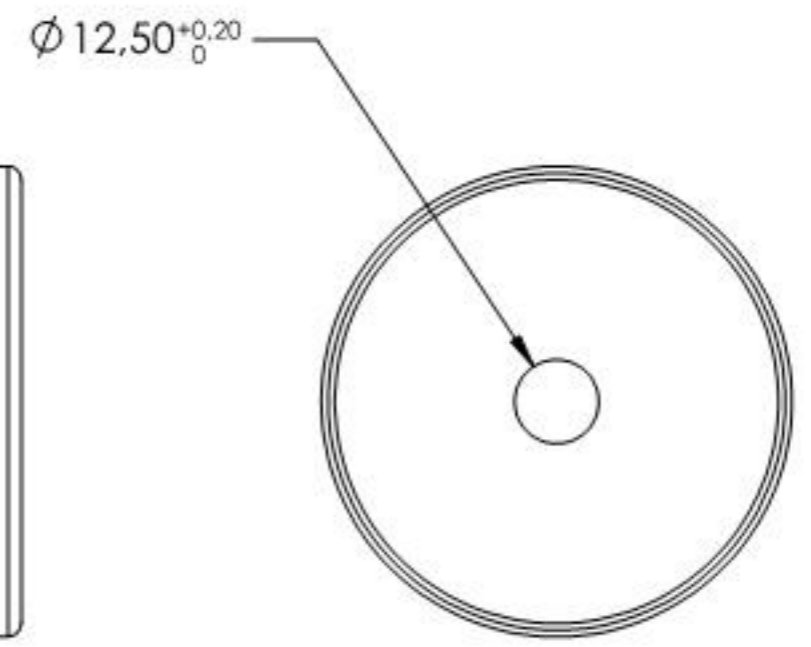
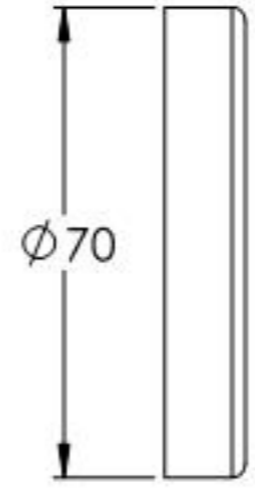
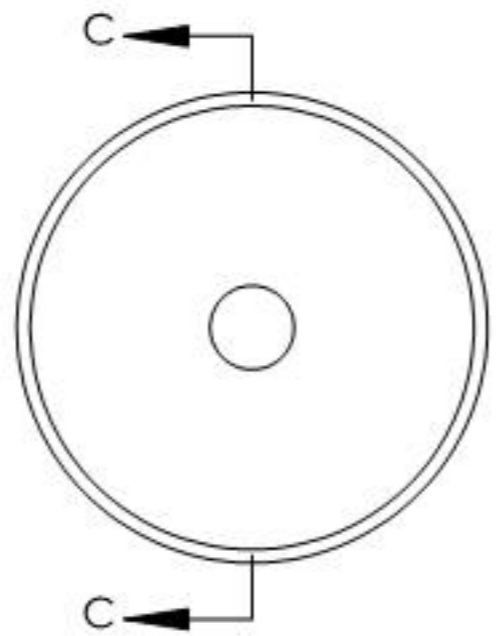
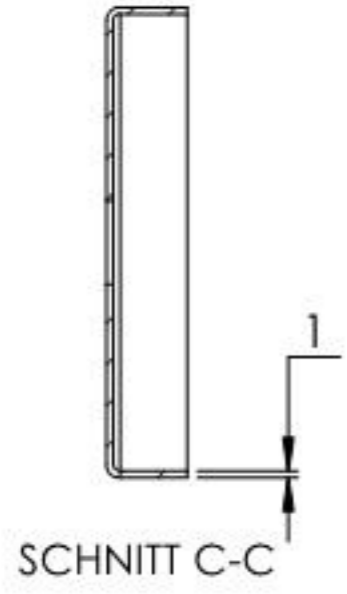
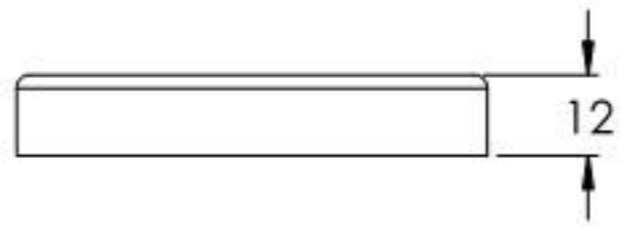

Name	Signatur	Datum	Artikelnummer	Oberfläche: Geschliffen Korn 240
Ch. Höfig	CH	08.02.2022	88.1160495.240	
Werkstoff: 1.4301 (X5CrNi18-10)				Blattformat A4
Gewicht 0.047 kg		Maßstab: 1:1,5 Version: 1		Blatt 3 von 6